

7W 6C33B-C SE OTL

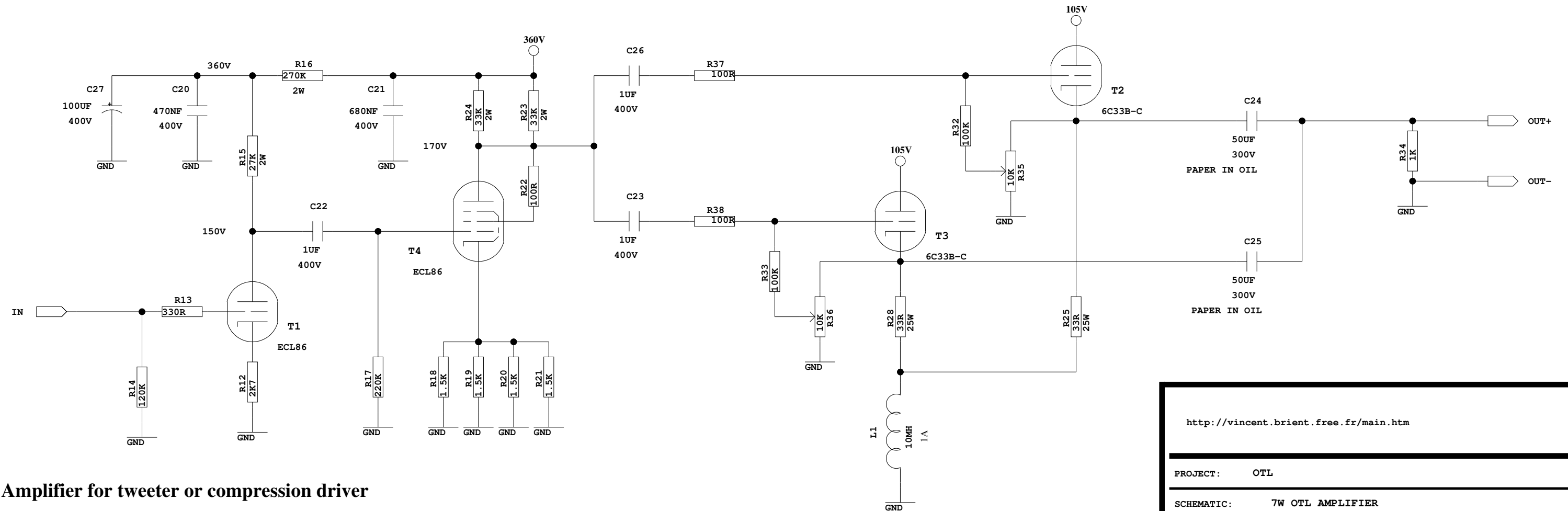

Amplifier for tweeter or compression driver

- 7W under 16ohm load
- Single ended - Class A - Triode amplifier
- No global feedback - No output transformer (OTL)
- 220Hz to 60KHz -3dB
- 8ohm output impedance
- 103dB SNR not weighted 400Hz-30KHz- 300mV sensitivity
- Note: set adjustable resistors to get 16V across both 33ohm resistors

<http://vincent.brient.free.fr/main.htm>

PROJECT: OTL

SCHEMATIC: 7W OTL AMPLIFIER

Date: 12/2007

Version: V1.1

Sheet : 1 / 1